



**The
California
State
University**
Office of the Chancellor

**Control Systems
Design Guideline**

Acknowledgement

The California State University (CSU) gratefully acknowledges the effort and work of Jai Agaram, Douglas Effenberger, Paulo Fundament, Malcolm Lewis, Kent Peterson, Steven Taylor and Satinder Gulati. Comments or inquiries may be directed to:

The California State University
Office of the Chancellor
Capital Planning Design and Construction
Long Beach, California
Attention: Thomas Kennedy, Chief Architecture and Engineering
Telephone: (562) 951-4129
E-mail: tkennedy@calstate.edu

Control Systems Design Guideline

INDEX

1.0 INTRODUCTION	4
1.1 Purpose of the Document.....	4
1.2 Control System Design Objectives	4
2.0 GUIDELINES FOR SYSTEM DESIGN.....	5
2.1 University Requirements	5
2.2 System Component Considerations	5
2.2.1 Controllers.....	6
2.2.2 Input Devices	7
2.2.3 Output Devices.....	9
2.2.4 Communication Interfaces	9
2.2.5 Operator Interface	10
2.3 Sequences of Operation and Input/Output Points.....	10
2.4 Installation.....	11
2.5 Commissioning	11
2.5.1 Control System Device Checkout and Testing	12
2.5.2 Control System Demonstration and Acceptance	12
2.6 Training.....	13
2.6.1 Project Specific Training	13
2.6.2 Ongoing Training.....	13
APPENDICES	14
Appendix 1 Accuracy, Calibration, Precision, Range, Scaling, Stability, and Tuning	15
Appendix 2 Sample Demonstration and Acceptance Specification Requirements	18
Appendix 3 Sample Installation Coordination Table.....	20
Appendix 4 Control System Design Example	25

Control Systems Design Guideline

1.0 INTRODUCTION

1.1 Purpose of the Document

This guideline is intended to provide the campus and designers of direct digital control (DDC) systems with background information, recommendations of good practice, and project considerations with respect to the design of a control system. This guideline is not intended to be a comprehensive manual for the design and specification of DDC systems. Other relevant California State University Guideline documents include:

Control Systems Procurement Guideline
Commissioning Guideline for CSU Capital Projects

The American Society of Heating, Refrigerating and air-conditioning Engineers, Inc. is a robust information resource on this subject matter. It has numerous published standards and guidelines on the engineering and specifications of controls and control systems. These include the following:

ASHRAE Guideline 13, Specifying Direct Digital Control Systems
Fundamentals of HVAC Controls, ASHRAE self-directed learning course

In addition to the references above, the appendix of this guideline contains sample diagrams and excerpts of specifications intended as examples to illustrate important concepts in the design and specifications of control systems.

1.2 Control System Design Objectives

The control system design should convey the following information:

- a. Campus standards
- b. System components required for proper function and operation
- c. Systems and equipment operation sequences
- d. Installation requirements
- e. Testing of control systems and components
- f. Operator training requirements

Control Systems Design Guideline

1.0 GUIDELINES FOR SYSTEM DESIGN

2.1 University Requirements

It is important for the control system designer to understand the current University control system requirements and design standards. Certain Campuses have set objectives on such issues as vendor preferences or requirements for interoperability and multiple vendor sources. The control systems designer must also assist the Campus in supplementing any preferences and standards with relevant technological advances that may be beneficial or advantageous to the control system design. This information should be integrated into the design documents.

The American Society of Heating, Refrigerating and air-conditioning Engineers, Inc. (ASHRAE) publishes a Guideline on Specifying Direct Digital Control Systems. ASHRAE Guideline 13 provides best practice recommendations for developing specifications for direct digital control (DDC) systems in heating, ventilating, and air-conditioning (HVAC) control applications.

2.2 System Component Considerations

A direct digital control system is a network of controllers, input devices, output devices, communication interface devices, and operator interface devices. It is important for the control system designer to subdivide the system design into well-defined descriptions and specifications of these system devices. Therefore, a clear understanding of system component and device differences, capabilities, application and requirements should be one of the important tasks in designing a suitable system for a single building or a campus wide application. A typical architecture for a direct digital controls system is shown in Figure 1.

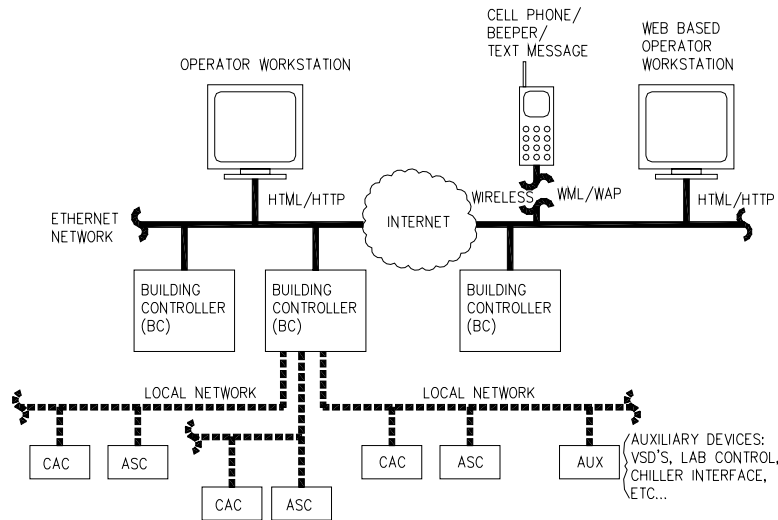

Figure 1 - Sample Control System Network Architecture

Control Systems Design Guideline

2.2.1 Controllers

Controllers are microprocessor-based computers that process information and communicate in a network with other controllers. Proper controller selection and specification will determine how well a control system will perform as a physical information processing network.

Selection and specification of system controllers should follow a categorization of these devices based on their functional requirements. Controllers are generally subdivided in three major categories: Building Controllers (BC), Custom Application Controllers (CAC), and Application Specific Controllers (ASC). The differences in these controllers are significant and should be well described.

- a. **Building Controllers (BC)** are designed to perform high level communications capable of connecting to local and wide area networks. Wide area network communications may include Internet communications. Building controllers must be capable of communication with other building controllers in the same building or other buildings across a Campus. These controllers must be fully user programmable. Complex sequence of operations should reside in building controllers. Networking capabilities, processing power, expansion capacity, and programmability of building controllers should be specified in detail.

In addition to high-level communications requirements, building controllers communicate with Custom Application Controllers and Specific Application Controllers via local sub-networks. Building controllers must also have capacity for numerous input and output points. Typical applications for Building Controllers include:

- Central cooling plants
- Central heating plants
- Large air handler systems

- b. **Custom Application Controllers (CAC)** are digital controllers with capacity to connect directly to numerous input and output devices. It must be fully programmable to accommodate building and equipment customized operating logic and sequence-of-operations. There should be no limitation in programmability of customized or building and equipment specific control loop and logic. Typical applications for custom application controllers include building air handling systems and pump stations.

Multiple communication capabilities should include direct communication with other CAC and BAC controllers on a high-speed communication platform such as Ethernet. Communication with multiple (at least three) sub-networks, each with the capacity to communicate with about one hundred (100) individual Application Specific Controllers, should be specified.

Control Systems Design Guideline

- c. **Application Specific Controllers (ASC)** are devices that communicate in the lower level building network and are dedicated to small, specific and repetitive applications. These often make up most of the controllers in a control system. ASCs often contain pre-programmed configurable software for specific applications. These controllers should be used for the intended applications. Modification to software and sequence of operations may be limited. The control system specifications should not allow use of these controllers for applications in central building equipment, such as air handlers, heat exchangers, chillers, boiler, and similar complex equipment. Typical applications for ASC's include:
- Zone fan-coil systems
 - Variable and constant volume terminal units
 - Unitary single zone units

Some campuses utilize industrial grade programmable logic controllers (PLC) instead of the DDC controllers described above. Some of the features of PLC's include superior reliability (high mean time to failure), superior loop control capabilities, including rapid processing rates exceeding 1/100 second per loop. Amazingly, the industrial controls market provides more standardized and further developed interoperability between different manufacturers than standard DDC controls. There are a number of different PLC communication protocols, some are proprietary while others are published and open. Modbus is a common PLC protocol utilized by a number for different manufacturers. Modbus has been evolving for the last 20 years or more and has a large installed base. For more information, please refer to www.modbus.org. It is not surprising that some large campuses have adopted PLC's running Modbus over TCP/IP. In spite of the apparent higher cost compared to DDC controls. In their case, the higher cost for PLC's is mitigated by greater reliability and more advanced interoperability.

2.2.2 Input Devices

Input devices are sensors that collect physical information such as temperature, pressure, level, position and other measurable properties. Proper selection and specification of input devices will determine the quality and accuracy of the physical data that is critical to the performance of a control system (refer to Appendix 1 for Sensor Accuracy, Calibration, Precision, Range, Scaling, and Tuning). Proper location and placement of input devices are also important issues to be understood and specified.

The information collected by sensors is converted into standardized electrical signal variables that are transmitted to controllers, where they are converted to digital signals. There are two major sensor sub-categories: analog sensors and binary or digital sensors.

Analog sensors measure physical variables that are expressed within a range such as temperature. Binary or digital sensors are switches or relays that indicate an on-or-off physical condition, such as whether a pump is running or not.

Control Systems Design Guideline

Table 1 provides some recommendations on sensor requirements in typical applications.

Table 1 – Sensor Range Recommendations

Measured Variable	Typical	
	Measurement Accuracy	Sensor Range
Space Temperature	±1°F	+50°F- +85°F
Ducted Air	±1°F	+50°F- +100°F
Outside Air	±2°F	-30°F- +130°F
Dew Point	±3°F	
Water Temperature		
- Chilled Water	±1°F	+25°F- +60°F
- Hot Water	±1°F	+60°F- +200°F
- High Temperature Water	±2°F	+200°F- +500°F
Differential Temperature	±0.25°F	
Relative Humidity	±5% RH	20% - 80%
Water Flow	±5% of full scale	
Airflow (terminal)	±10% of full scale	
Airflow (measuring stations)	±5% of full scale	
Airflow (pressurized spaces)	±3% of full scale	
Air Pressure (ducts)	±0.1 in. w.g.	0 - 5.0 in. w.g.
Air Pressure (space)	±0.01 in. w.g.	-0.25 - 0.25 in. w.g.
Water Pressure	±2% of full scale	
Electrical (A, V, W, Power Factor)	5% of reading	
Carbon Monoxide (CO)	±5% of reading	0 - 1,000 ppm
Carbon Dioxide (CO2)	±50 ppm	0 - 1,000 ppm

The placement or location of specific control sensors can be critically important to how well a particular control system functions. In a variable air volume fan system where fan speed is adjusted based on zone static pressure demand, the placement of the static pressure system should be placed as close to the end of the ductwork system as possible. The furthest location from the fan provides the best indication of actual demand and affords the most variable air volume reduction. This same concept applies to variable pumping systems. The differential pressure sensor should be as far from the pump as possible. In systems where multiple duct and piping branches end in various locations, sensors should be installed at each representative end. A signal selector routine should be used to determine the lowest reading and should govern the fan or pump speed accordingly. More information on the issue of proper placement of sensors is provided in the ASHRAE Applications Handbook Chapter 46, Design and Application of Controls.

Whenever possible the designer should specify current sensing relays for verification of motor running status. The utilization of current sensing relays is more reliable than auxiliary contacts for this purpose.

Control Systems Design Guideline

2.2.3 Output Devices

Output devices are mechanical and electrical instruments and equipment that assume an operating condition commanded by a controller.

Output devices are generally sub-divided in two categories: digital or binary outputs and analog outputs. Digital outputs are binary commands (usually a dry contact) to start or stop equipment operation. Digital outputs can also be used to control floating type (drive-open, drive-close) modulating actuators. Analog output points produce modulating signals to control or set position of modulating valves, dampers, VFDs, etc. Proper selection and specification of output devices largely determine the effectiveness of a control system

Control valves for chilled water, heating hot water and steam applications must be properly specified. Generally valves with equal percentage flow characteristics should be specified. Quick opening valves should be avoided for modulating applications. Pressure balanced valves do not transfer fluid pressure to the stem and valve actuator. Specify pressure balanced valves whenever fluid pressure conditions may interfere with the actuator's ability to properly position the valve stroke.

Duct mounted control dampers for static pressure or volume controls should be specified with opposed blades. Parallel blade damper configurations should be avoided as the flow characteristics of opposed blade dampers are more favorable to proper control. The 2001 ASHRAE Fundamentals Handbook Chapter 15, Fundamentals of Control contains more detailed information including proper selection of valves and dampers.

2.2.4 Communication Interfaces

The arrangement of control systems and how they are linked together in a network is called "system architecture" (refer to figure 1 "Sample Control System Network Architecture" in section 2.2). Selection of the physical media (wires) and communication protocol is an individual choice at each campus. Communication network details are particularly important in campus where interoperability of devices provided by different control manufacturers is a goal or requirement. Interoperability of control systems is the reliable and timely function of reading and writing data between the systems and devices from different manufactures. ASHRAE Guideline 13 addresses these in detail and should be referred to for proper consideration of campus project needs. Also see the *CSU Control Systems Procurement Guide*.

The majority of control systems today utilize LAN (Local Area Network) technologies for communications/networking. Consultation with manufacturers being considered to determine specific needs and with campus network managers to determine ability to accommodate is essential. The use of a dedicated LAN is always a safe option but may be cost-prohibitive. Therefore, the ability of the campus network administrators to accommodate system needs with existing

Control Systems Design Guideline

networks can be the most cost-effective approach. Networking of systems reference data can also be found in ASHRAE Guideline 13.

2.2.5 Operator Interface

The operator interface is determined by what the system operators will see when they interface with the system. Specific considerations should be applied as outlined in ASHRAE Guideline 13.

Strategically locate operator interface console in places that provide high visibility and easy access to operating engineers. Control rooms which are an integral part of a central plant, or common rooms where most operating engineers congregate during some portion of the day are examples of good visible locations.

The designer should specify that operator interface software must include graphical diagrams with pertinent system points values refreshed at a rate of no more than 10 seconds. Hyperlinks within graphics should display description of pertinent sequence of operations.

2.3 Sequences of Operation and Input/Output Points

The sequences of operation, supported by input and output points lists, and controls schematic diagrams, should describe how systems shall function and should serve as the designer's primary method of communication to the control system contractor. A sequence of operation should be written for each system to be controlled. All operational modes should be described to ensure that all input and output devices needed to implement the proposed sequences are shown on the point list and drawings. Sequences should detail how the system operates in each mode, including part load, full load, normal, occupied, unoccupied, summer, winter, and emergency. Energy conservation strategies should also be described in control sequences. Therefore, sequence of operations, input and output points lists and schematic diagrams constitute the most important elements of a control system design.

The following organizational suggestions are provided to aid the designer in developing the sequences of operation:

- a. Provide a description of the system at the beginning of each section to assist the reader in understanding the system. This should include unusual or custom system or control requirements to help explain the rationale behind sequences
- b. Organize sequences into the logical hierarchy of systems and the subsystems they serve. The most energy efficient sequences start at the lowest level and feed operational requests upwards. For example, zone VAV control logic determines the need for heating and cooling, which is conveyed to the air handler that serves them so that they operate as desired. The air handler control logic in turn conveys the need for chilled and hot water to the central cooling and heating plants. In this way systems operate efficiently and at the lowest part load possible.

Control Systems Design Guideline

- c. Organize sequences into modes of operation, then describe how each controlled device is to operate in each mode. For instance, an air handler might have the following modes: occupied, warm-up, cool-down, setback, set-up, and unoccupied. For each mode, describe how the fans, dampers, control valves, etc. should operate.
- d. Use tables and diagrams where possible to assist in conveying sequencing logic.
- e. Show formulas in the sequences if they are to be used in calculations.
- f. Write the sequences in such a way that it will make it easy to use the document to verify control system functionality during construction and testing.
- g. Control loop initial or default set points should be provided.
- h. Keep the sequences as simple as reasonably possible
- i. Refer to Appendix 4 “Control System Design Example” for a sample control schematic, DDC points list and controls sequence of operations.

2.4 Installation

The installation of control systems involves work among many contractors and subcontractors on a project. It is common for the division of responsibilities to be poorly coordinated. The general contractor is responsible for making sure all aspects of the control system project are covered once by each of his subcontractors, but in practice, that seldom happens due in part to the complexity of DDC systems, the many areas where responsibilities among trades connect or overlap, and due to the nature of bid work where bids and proposals from subcontractors are provided to the bidding contractor too close to bid time for proper coordination to take place.

It is advantageous if the control system scope among subcontractors is well defined. One way that this can be done is by including a coordination table in the General sections of Divisions 15 or 16, with references in related sections. An example of such a table is provided in appendix 3.

2.5 Commissioning

Control system commissioning is essential to provide a functional system to the campus. Incomplete commissioning of the temperature control/building automation systems compromises the total benefit provided by a proper commissioning effort. Overlooking even the small details may result in sub-optimal system operation. Conversely, thorough control functional testing before occupancy may uncover hidden deficiencies that require improvement in adjustment or changes to the sequence of operation.

The *CSU Commissioning Guideline for Capital Projects* outlines the commissioning process and it identifies project contributor responsibilities and tasks to be performed.

Control Systems Design Guideline

2.5.1 Control System Device Checkout and Testing

It is recommended that the requirement for the contractor to conduct the following testing be included in the controls specifications. This testing should be completed before system demonstration to the commissioning agent.

- a. Calibrate and prepare for service of all instruments, controls, and accessory equipment furnished under the project specifications. Specifications should be clear which sensors must be field calibrated and with what type of equipment. It is not necessary on most projects to field calibrate all sensors; factory calibration is generally acceptable for non-critical sensors, such as zone temperature sensors in offices.
- b. Verify that all control wiring is properly installed and connected.
- c. Enable the control systems and verify calibration of all input devices individually. Perform calibration procedures according to manufacturers' recommendations.
- d. Verify that all binary output devices (relays, solenoid valves, two-position actuators and control valves, magnetic starters, etc.) operate properly and that the normal positions are correct.
- e. Verify that all analog output devices are functional with proper output signal range, and default value settings.
- f. Alarms and Interlocks:
 1. Check each alarm separately by including an appropriate signal at a value that will trip the alarm.
 2. Interlocks shall be exercised using field contacts to check logic, as well as to ensure that the fail-safe conditions are properly set.
 3. Interlock actions shall be tested by simulating alarm conditions to check for proper interlock action.

2.5.2 Control System Demonstration and Acceptance

It is recommended that the design engineer specify that the control system functionality be demonstrated to the engineer and campus representatives prior to acceptance. It is important to demonstrate to the University operating engineers that the system and its components as installed and previously tested meet the requirements of the contract documents in all respects. Therefore, many of the tests previously performed by the subcontractor may be repeated for demonstration and/or documentation to the University.

Control Systems Design Guideline

The sample specification language (Refer to Appendix 2 “Sample Demonstration and Acceptance Specification Requirements”) requires that the University representative be present to witness all tests demonstrating all aspects of system performance. The time commitment required for this will be extensive and should be discussed with the campus when writing the specifications. If the commitment cannot be met, then the specification should be modified to clarify how much of the system should be demonstrated. Either way, all forms and checklists prepared or completed by the subcontractor are required by the specification for submission and approval.

2.6 Training

2.6.1 Project Specific Training

Operator training requirements should be fully reviewed with campus staff to determine specific campus needs. Training options are numerous. Specific training project requirements should be specified in the control system specification. Comprehensive training curricula and syllabus should be submitted from the contractor to the University for review, revision and approval. The syllabus should identify training topics along with associated amount of training time per topic. Project specific training can be generally categorized as follows:

Introductory training should be designed to introduce the DDC system to the operators. The typical length of this class is two to five days.

Hands-on operator training should be designed to make the operators familiar with the sequences of operation and comfortable with operating the DDC system. This mode of training should be conducted on site using the installed DDC system. The typical length of this class is three to five days.

Advanced training should be designed to make the operators comfortable with advanced functions such as programming the system. The typical length of this class is one to two weeks.

2.6.2 Ongoing Training

Control system vendors frequently offer training programs on new systems, software upgrades, control sequences, and other relevant issues. A campus is encouraged to establish an ongoing training program. This program should include a suitable budget and staff time allocation.. Project specific and ongoing training reduces dependency on control manufactures and contractor services, and it increases the value of a control system. Ongoing training can be generally categorized as follows:

Annual software and programming training. This typically involves one week and two campus staff.

Annual hardware equipment and network devices training. This typically involves one week and two campus staff.

Control Systems Design Guideline

APPENDICES

The purpose of appendices included in this guide is to provide further discussion and background information on important topics related to proper control system design and function. Many aspects of modern DDC control systems are related to recent advances in computer technology. Other equally important control aspects related to basic physics and control functions are not borne out of recent technological advancements. Therefore, proper control system design requires not only expertise recent technology but also ample expertise in control system fundamentals.

Control Systems Design Guideline

Appendix 1

Accuracy, Calibration, Precision, Range, Scaling, Stability and Tuning

It is important to clearly convey the distinct definitions of these fundamental control aspects and definitions in order to produce an effective design. The following are some important fundamental control definitions and descriptions.

Accuracy is the ability of a measurement to match the actual value being measured. It is different from calibration in that accuracy indicates the ability of a sensor to read a physical property. A sensor's accuracy cannot be overcome by calibration. A less accurate sensor may detect temperature changes in single Fahrenheit degrees. A more accurate sensor may detect temperature changes 1/10 of Fahrenheit degrees.

Calibration is the act of checking or adjusting the accuracy of an instrument by comparison it with a known standard. As an example, a temperature sensor should display 32°F when immersed in an ice bath. The ice bath is the known standard. Adjustments to a temperature sensor may be necessary if it does not produce a reading of 32°F when immerse in an ice bath. Calibration of an instrument, such as the temperature sensor example, should be made at two or more points to assure proper slope adjustment. Therefore, the example sensor should display 212°F when immersed in boiling water. If this sensor displays 32°F in an ice bath and 212°F in boiling water, it can be said that it is calibrated.

In modern controls, temperature sensors are calibrated to produce the correct output of voltage, resistance, or amperage correlated to the temperature of the medium to be measured (e.g., air, water). All sensors for temperature and pressure measurement must be calibrated. Some are factory calibrated and certified, others require field calibration, and often using a device called a dry-well. A common preventative maintenance task is to check calibration of sensors regularly

Suggestions for ongoing sensor calibration checking are itemized as follows:

- Points that should be checked on a monthly basis include energy meters, main plant flow devices.
- Points that should be checked on a quarterly basis include duct temperature sensors and control valves.
- Points to be checked on a yearly basis include zone sensors.

Precision is the ability of an instrument to produce a repeatable and reliable measurement or output consistently. A precise controller produces a repeatable output signal given equal input conditions.

Range is the extent of measurements that a sensor can display accurately. For instance, a certain temperature sensor may be specified to measure accurately between 32°F and 212°F. For temperatures below 32°F, it may produce erratic or non-linear readings, and for temperatures above 212°F, the sensing element may become damaged and or produce erratic values. In this case, the sensor range for accurate readings is from 32°F to 212°F. Narrow ranges contribute to greater accuracy of measurement. For a space temperature measurement application, a sensor

Control Systems Design Guideline

with a range of +40 to +140°F is much more appropriate than a sensor with a range of 0 to +250°F.

Scaling of a sensor is the conversion of its output signal (voltage, amperage, or resistance) into digital intervals. A four-bit converter has only 16 interval steps. For the previous example of a temperature sensor, 32°F would correspond to an output of 0000, and 212°F would correspond to an output of 1111 in the analog to digital converter. A four bit converter sacrifices significant accuracy by only being able to output 16 discrete steps between 32°F and 212°F. It can only output the following discrete temperature values: 32, 43.25, 54.5 etc. In contrast, a 32-bit analog to digital converter retains much more accuracy than a four-bit converter.

Stability is the ability of a process variable such as temperature, pressure, or flow rate to maintain a steady equilibrium. Stability is a condition derived from proper tuning; however stability is not to be considered evidence of proper tuning. In an HVAC system a controlled air or water temperature or pressure can maintain a steady state under one set of circumstances and not in others. A building system may function well on cold days and may function poorly on warmer days.

Tuning is the individual adjustment of the proportional gain, the integral gain, and the derivative gain, of a modulating control system, in order to optimize control performance by minimizing control offset error, increasing speed of response, and increasing stability of the process being controlled. Tuning is specific to the particular process such as an HVAC system being controlled. A properly tuned control system provides greater control accuracy, operational stability, and usually more energy-efficient operation of the system. Tuning can be strait forward for simple processes, especially those not including integral and derivative functions. For more complex processes such as variable volume static pressure and differential control typically found in large fan rooms and central plants proper tuning is essential and often overlooked. Poor tuning leads to hidden system performance issues and substantial energy waste. A properly tuned process produces the most rapid control corrections without producing process oscillations. An example of specification statements that require demonstration of proper tuning is as follows:

- a. Software and /or hardware shall be provided by which an operator can place a control loop into a test mode. While in test mode, the operator shall be able to vary all associated loop control parameters and in either a graphically or tabular format observe the control loop response. Automatic tuner functions can assist the tuning process, however automatically tuned processes must demonstrate tuning quality as manually tuned processes.
- b. The Contractor shall initially and properly tune all PID and PI parameters. Quality of tuning will not be based on mere process stability, but on actual critical damping performance on system excitation. Over and/or under shooting upon excitation will not be acceptable.
- c. The Contractor shall provide hard copy trend graphs for all PI and PID loops shown individually. Each graph shall demonstrate that the corresponding loop processes does not under-or-over shoot its correction given 20% set point change at mid-range. Graph time coordinate shall be within two to ten times the natural system time constant. The system output coordinate shall be scaled to no more than 100% of output range.

Control Systems Design Guideline

- d. Initial Trending of Points and System Conditions: During acceptance and system commissioning, contractor shall provide trending of all controlled and input points for intervals of no less than 5 minutes continuously over a representative 48 period. This tabulation shall be presented in printed form with clear annotation of point descriptions and values. PID loop tuning shall be demonstrated by tabular and graphic representation of system response charts indicating control variable recovery upon excitation.. Trending tables and graphs shall be resubmitted as necessary to substantiate proper system calibration, tuning and operation, before conclusion of project acceptance.

Control Systems Design Guideline

Appendix 2

Sample Demonstration and Acceptance Specification Requirements

A. Demonstration

Prior to acceptance, the control system shall undergo a series of performance tests to verify operation and compliance with this specification. These tests shall occur after the Contractor has completed the installation, started up the system, and performed his/her own tests.

The tests described in this section are to be performed in addition to the tests that the contractor performs as a necessary part of the installation, start-up, and debugging process and as specified in the "Control System Checkout and Testing" article in Part 3 of this specification. The engineer will be present to observe and review these tests. The engineer shall be notified at least 10 days in advance of the start of the testing procedures.

The demonstration process shall follow that approved in Part 1, "Submittals." The approved checklists and forms shall be completed for all systems as part of the demonstration.

The contractor shall provide at least two persons equipped with two-way communication and shall demonstrate actual field operation of each control and sensing point for all modes of operation including day, night, occupied, unoccupied, fire/smoke alarm, seasonal changeover, and power failure modes. The purpose is to demonstrate the calibration, response, and action of every point and system. Any test equipment required to prove the proper operation shall be provided by and operated by the contractor.

As each control input and output is checked, a log shall be completed showing the date, technician's initials, and any corrective action taken or needed.

Demonstrate compliance with Part 1, "System Performance."

Demonstrate compliance with sequences of operation through all modes of operation.

Demonstrate complete operation of operator interface.

Additionally, the following items shall be demonstrated:

DDC loop response. The contractor shall supply trend data output in a graphical form showing the step response of each DDC loop. The test shall show the loop's response to a change in set point, which represents a change of actuator position of at least 25% of its full range. The sampling rate of the trend shall be from 10 seconds to 3 minutes, depending on the speed of the loop. The trend data shall show for each sample the set point, actuator position, and controlled variable values. Any loop that yields unreasonably under-damped or over-damped control shall require further tuning by the Contractor.

Operational logs for each system that indicate all set points, operating points, valve positions, mode, and equipment status shall be submitted to the architect/engineer. These logs shall cover three 48-hour periods and have a sample frequency of not more than 10 minutes. The logs shall be provided in both printed and disk formats.

Control Systems Design Guideline

Any tests that fail to demonstrate the operation of the system shall be repeated at a later date. The contractor shall be responsible for any necessary repairs or revisions to the hardware or software to successfully complete all tests.

B. Acceptance

All tests described in this specification shall have been performed to the satisfaction of both the engineer and University prior to the acceptance of the control system as meeting the requirements of completion. Any tests that cannot be performed due to circumstances beyond the control of the contractor may be exempt from the completion requirements if stated as such in writing by the engineer. Such tests shall then be performed as part of the warranty.

The system shall not be accepted until all forms and checklists completed as part of the demonstration are submitted and approved as required in Part 1, "Submittals."

Control Systems Design Guideline

**Appendix 3
Sample Installation Coordination Table**

The following table is provided as an example of an installation coordination table indicating installation responsibility by CSI specification subcontractor sections. Please note that the table covers most MEP coordination items.. If this table is used in contract documents, it is essential that:

The specification must be edited very carefully to make it project specific. Coordination is not done the same way on all projects and many lines in the table will not apply.

Designers must be made aware of the table and customize their drawings and specifications to be consistent with it. For instance, if the table says that power to control panels is provided by Division 16, the electrical drawings must show and/or specify this work.

This table is intended to assist the Contractors in coordinating the scope of work between Division 15 HVAC (indicated as 15 in table), other sub-divisions of Divisions 15 such as Plumbing (indicated as 15P), Fire Sprinkler (indicated as 15FS), and 15900 DDC (indicated as 15C), and other Divisions as indicated. However, the General Contractor is ultimately responsible for coordination among his subcontractors regardless of what is listed in this Section.

INTERFACE / RESPONSIBILITY MATRIX					
System	Division under which the following is specified				Remarks
	Equipment	Installation	Power wiring (note 1)	Control & interlock wiring (note 1)	
Fire Sprinkler System					
Flow switches	15FS	15FS	16	16	
Valve monitors	15FS	15FS	16	16	
Post indicating valves	15FS	15FS	16	16	
Fire & Life safety SystemS					
Fire alarm and smoke control systems	16	16	16	16	
Duct mounted & in-duct mounted smoke detectors	16	15	16	16/ 15C	2
Other smoke detectors	16	16	16	16	
Smoke dampers with electric actuators	15	15	16	16	
Smoke damper end switches	15	15	16	16	3
Mechanical Equipment					
Packaged mechanical equipment	15	15	16	16/15	4,
Chillers	15	15	16	15C	4, 7
Air compressors	15	15	16	15	4
Variable speed drives, field mounted	15	16	16	16/ 15C	
Motors, 3 phase	15	15	16	–	

Control Systems Design Guideline

INTERFACE / RESPONSIBILITY MATRIX					
System	Division under which the following is specified				Remarks
	Equipment	Installation	Power wiring (note 1)	Control & interlock wiring (note 1)	
Motor starters, 3 phase	16	16	16	16/ 15C	5
Motors, 1 phase	15	15	16	16/ 15C	6
Other powered equipment	15	15	16	15C	
Disconnects	16	16	16	16	
Refrigerant leak detector	15C	15C	16	15C	8
Cooling tower vibration switch	15	15	–	15C	
Cooling tower water treatment system	15	15	16	15C	
Energy Management & Control System (DDC)					
Central control workstations	15C	15C	16	15C	
Control panels	15C	15C	15C	15C	9
Control devices	15C	15C	15C	15C	
Lighting relay panels	15C	16	16	15C	10
Lighting wall mounted switch stations	16	16	16	16	
Lighting occupancy sensors	16	16	16	16	
Delighting sensors and controls	16	16	16	16	
Power monitoring sensors and gateway	16	16	16	16/ 15C	11
Plumbing Systems					
DHW heater venting and combustion air	15	15	–	–	
Condensate drains including traps, primers	15P	15P	–	–	12
Make-up water to hot/chilled/condenser water including back-flow prevention	15P	15P	–	–	13
Natural gas connections, pressure reducing station, gages	15P	15P	–	–	14
Gas and water flow meters	15C	15P	15C	15C	
Re-circulation pumps	15P	15P	16	15C	
Pipe gauges and thermometers	15P	15P	–	–	
Self-powered valves, pressure relief valves, liquid level controllers, etc.	15P	15P	–	–	
Sensor wells, meters, and other pipe-mounted control devices	15P	15P	15P	15P	
Test plugs	15P	15P	–	–	15
HVAC Hydronic Systems					
Pipe gauges and thermometers	15	15	–	–	
Self-powered valves, pressure relief valves, liquid level controllers, etc.	15	15	–	–	
Automatic isolation and control valves	15C	15	15C	15C	
Sensor wells, meters, and other pipe-mounted control devices	15C	15	15C	15C	
Test plugs	15	15	–	–	15

Control Systems Design Guideline

INTERFACE / RESPONSIBILITY MATRIX					
System	Division under which the following is specified				Remarks
	Equipment	Installation	Power wiring (note 1)	Control & interlock wiring (note 1)	
HVAC Sheet metal					
Duct mounted sensors	15C	15	15C	15C	
Filter gages	15	15	-	-	
Grease hoods	10	10	-	15C	16
Grease duct rated enclosures or fire wrap	9	9	-	-	
Control dampers	15	15	15C	15C	17
Control damper actuators	15C	15C	15C	15C	17, 18
vav packacked air conditioning Systems					
AC unit controls including controls	15	15	15	15	
Gateway to DDC	15	15C	16	15C	19
computer room air conditioning Systems					
AC unit controls including controls, valves, etc.	15	15	15	15	
Gateway to DDC	15	15C	16	15C	19
Laboratory HVAC Systems					
Exhaust hood air valves, actuators and controls	15	15	15	15	20
Supply air fan-coils with control transformer	15	15	16	15	20
HW and CHW valves, actuators and controls	15	15	15	15	20
Gateway/router to DDC	15	15	16	15	20
HVAC Terminal Boxes					
Terminal box control transformer panel	15C	15C	15C	15C	9
Terminal box with damper	15	15	-	-	
Digital controller and damper actuator	15C	15	15C	15C	21
Wall sensor module	15C	15C	15C	15C	
Air-flow measurement pickup and piping	15	15	-	-	
Air-flow measurement transducer and wiring	15C	15C	15C	15C	
Terminal fan, including contactors & control transformer	15	15	16	15	22
Electric reheat coil, including control transformer, safeties & contactors	15	15	16	15	22
HW control valve and actuator	15C	15	15C	15C	
Architectural					
Louvers	7	7	-	-	
Combination Louver/dampers	15	15	15C	15C	
Concrete housekeeping pads, curbs, pedestals and inertia base fill etc. for equipment.	3	3	-	-	23
Framing of walls and ceilings to accept air outlets, fire dampers, etc.	9	9	-	-	24
Ceiling and wall access doors	8	8	-	-	25

Control Systems Design Guideline

NUMBERED REMARKS:

1. Wiring includes raceway, fittings, wire, boxes and related items, all voltages
2. Wiring of interlock of duct smoke detectors to shut off supply fans upon detection of smoke is specified under DDC Section, except for CBC 905 life safety systems, such wiring is specified under Division 16
3. End switch required only for monitoring position of damper for CBC 905 life safety systems only. See HVAC drawings and Division 15 smoke damper specifications to see where required
4. Factory installed starters and/or variable speed drives are specified under Division 15. Prewired control panel is specified under Division 15; single point power connection (unless otherwise noted on drawings) specified by Division 15
5. For motors that are not covered by note 4; integral starter control devices such as HOA switches, 120V control transformers, and time delay relays (from high to low speed) for two speed motors specified under Division 16
6. Single phase 120V motors with integral motor overload protection specified under Division 15; line voltage control device such as thermostat or switch specified under DDC Section; wiring and conduit between control device and motor specified under Division 16
7. Chilled and condenser water flow switches (where required by chiller manufacturer) specified under Division 15; wiring and conduit specified under DDC Section; bi-directional (read/write) BACnet gateway between the DDC and chiller control panels specified with chiller under Division 15; installation, power wiring, and control wiring specified under DDC Section; chiller vendor to provide all necessary technical assistance to DDC Section Contractor in mapping across chiller points to the DDC
8. Emergency override switches, status lights, and other refrigerant machinery room controls as required by CMC specified under DDC Section
9. DDC Section contractor to coordinate with Division 16 contractor for power to panels, but work is specified under DDC Section
10. Line-voltage controlled circuit connections to and from lighting panel relays are specified under Division 16
11. Power measuring sensors, installation, and wiring to a central controller with BACnet or Modbus gateway to DDC specified under Division 16; with network connection specified under DDC Section; power monitoring control vendor to provide all necessary technical assistance to DDC Section Contractor in mapping across power monitoring control points to the DDC
12. Condensate piping from condensate pans to the sewer system including trap and final connections is specified under Division 15 Plumbing. Piping from auxiliary drain pans where they are required at fan-coils in furred spaces is specified under Division 15 HVAC.
13. Domestic make-up water, including shut-off valve, back-flow prevention, rough-in and final connection to hot water, chilled water, condenser water, and any other HVAC systems requiring make-up water is specified under Division 15 Plumbing. Pressure reducing valves with bypass valve and shut-off valves at each closed-system make-up water connection are specified under Division 15 HVAC.
14. Pressure reducing valves to deliver gas at the pressure required by mechanical equipment, including final connections and shut-off cock, is specified under Division 15 Plumbing. All other gas control and regulating devices provided under the Section providing the gas-fired equipment. Venting of gas regulating devices and other equipment gas-train devices where required is specified under Division 15 Plumbing.
15. Test plugs mounted adjacent to all temperature wells (for calibration) specified under Division 15.
16. Hoods, including all fire protection devices (e.g. dampers at outlets), are specified under Division 10 Food Service. Duct connection to hood from collar on to exhaust fan specified under Division 15 HVAC. All related control wiring, switches, etc. specified under Division 15 DDC.
17. Duct access doors required for access to control devices where required specified under Division 15.
18. Actuators for motorized dampers supplied with fans where scheduled on HVAC drawings are specified under Division 15, mounted but not wired.
19. BACnet gateway to DDC specified in the Division 15; with connection of gateway to AC units and from gateway to DDC specified under DDC Section. AC vendor to provide all necessary technical assistance to DDC Section Contractor in mapping AC control points to the DDC.
20. Laboratory controls including all temperature and airflow controls specified in Division 15; BACnet router/gateway to DDC specified in the Division 15; with network connection specified under DDC Section; laboratory control vendor to provide all necessary technical assistance to Section Contractor in mapping

Control Systems Design Guideline

- laboratory control points to the DDC
21. DDC Section contractor to coordinate with Division 15 contractor to have controller and actuator factory mounted
 22. Factory wired control transformer, safeties, and contactors with single point power wiring connection specified under Division 15
 23. Shop drawings showing dimensions of all curbs, bases, etc. specified under Division 15
 24. The ceiling contractor shall provide additional T-bar or spline and cut ceiling tile as required to accept air outlets
 25. Access doors to mechanical equipment shall be dimensioned by installing subcontractor and coordinated with architect and wall/ceiling contractor

Control Systems Design Guideline

**Appendix 4
 Control System Design Example**

This appendix shows the DDC system design for an example application, including a schematic, points list, and control sequence. This example is intended to illustrate the desired level of detail for CSU control system specifications.

Control Schematics

The schematic system is a single zone air handler using central hot and chilled water. The control points are not labeled in words in this schematic, but rather are tagged for reference to the points list table where the point is further described.

This schematic is not intended to imply that only this format is acceptable for CSU projects; any format that shows the location of the device schematically and that indicates either a point description or tag is acceptable.

An outdoor air temperature sensor, which is necessary for some of the control logic below, is not shown in the schematic since it is assumed that a single sensor located centrally is used for all systems in the building.

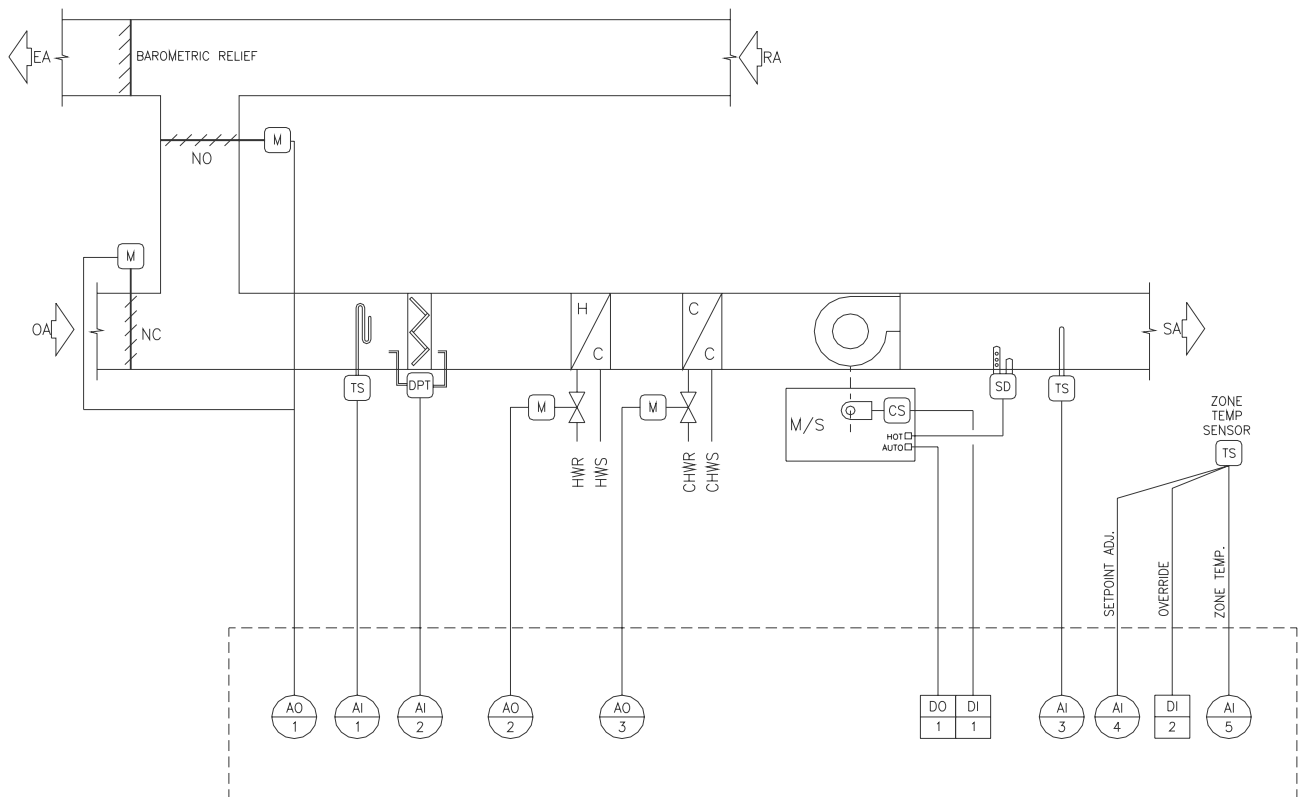

Sample Control Schematic

Control Systems Design Guideline

Control Points List

The table below shows one of many acceptable formats for displaying Input/Output points for the example single zone unit. In this example, the following features associated with points are included:

Description. This is simply a description of the point so its function is apparent.

Point type. The type of point must be noted (analog or binary, input or output). In this case, only hardware (real) points are listed. Software points (also called pseudo points), that are used internal to the controller for set points and other control functions, could also be listed. The advantage of doing so is that trending requirements and other attributes can be specified for these points, but it also requires significant additional work on the part of the designer and it implies that the software point list is complete, often causing change order requests when additional software points are requested to be trended.

Device. This column references devices specified elsewhere in the specifications. It is recommended that devices be tagged so that it is clear what device is required for each application. For instance, several pressure transmitters may be specified each with varying ranges of accuracy or operating range. Tagging them will ensure the right sensor is used on the right location.

Trend Logging. Trending data is extremely useful during commissioning as a part of functional testing, and later as a diagnostic tool if some equipment or software malfunctions. If trending is to be used for either purpose it must be specified since with many systems, configuring trends is very time consuming; asking for it post-bid will incur significant added costs. For each trend column, list either the desired trending time interval or change of value (COV, for binary points) and differential value change (for analog points). Other features that can be included in points lists are:

Graphic assignment, to indicate if and which graphic the point should appear in. If not included, specify that all real and software points associated with a system be included on the graphic.

Alarms, often specified as a range of values above or below which an alarm should be generated. Alarms can also be included in control sequences, which has the advantage of allowing more detailed qualification and level of the alarm, e.g. generate a high level alarm when supply air temperature is out of range but only if the AHU is on and has been operating for x minutes.

Control logic, such as setback, optimum start, etc. This is better placed in control sequences where the detail of the logic can be specified.

Control Systems Design Guideline

Sample DDC Points List

Description	Type	Device	Trend Logging		Calibration
			Cx	Continuous	
Supply Fan Start/Stop	DO-1	Dry contact to 120 V starter or motor power circuit.	COV	COV	–
Economizer Dampers	AO-1	Modulating actuators	1 min	15 min	–
Hot Water Control Valve	AO-2	Modulating 2-way valve	1 min	15 min	–
Chilled Water Control Valve	AO-3	Modulating 2-way valve	1 min	15 min	–
Supply fan status	DI-1	CS-1	COV	COV	See specs
Zone Override	DI-2	TS-3C	COV	COV	–
Mixed Air Temperature	AI-1	TS-1B across filter bank	1 min	15 min	F
Filter Pressure Drop	AI-2	DPT-3A, 0 to 1”	–	60 min	F
Supply air temperature	AI-3	TS-1A	1 min	15 min	F
Zone Temperature Set point Adjustment	AI-4	TS-3C	15 min	60 min	F
Zone Temperature	AI-5	TS-3C	1 min	15 min	F

Control Sequence

The level of detail in control sequences varies. The example sequence below is on the more detailed side, but as noted in the body of this manual, the more detailed, the better in most cases.

Single Zone Unit Sequence of Controls

Set points

Each zone shall have separate unoccupied and occupied set points, and separate heating and cooling set point.

As a default, the occupied heating set point shall be 70°F and the occupied cooling set point shall be 74°F.

As a default, the unoccupied heating set point shall be 60°F and the unoccupied cooling set point shall be 90°F.

The software shall prevent:

The heating set point from exceeding the cooling set point minus 1°F (i.e. the minimum dead-band shall be 1°F);

The unoccupied heating set point from exceeding the occupied heating set point; and

The unoccupied cooling set point from being less than the occupied cooling set point.

Where the zone has a local occupant adjustable set point adjustment knob/button:

Control Systems Design Guideline

The adjustment shall be capable of being limited in software.

As a default, occupied cooling set point shall be limited between 72°F and 80°F.

As a default, occupied heating set point shall be limited between 65°F and 72°F.

The adjustment shall move both the existing heating and cooling set points upwards or downwards by the same amount unless the limit has been reached.

The adjustment shall only be active in Occupied mode.

If a demand limit set point adjustment is in place or the window switch indicates the window is open, the local set point adjustment shall be disabled.

Demand limit set point adjustment. Cooling set points shall be increased upon demand limit requests from the associated System.

At Demand Limit Level 1, increase current set point by 1°F.

At Demand Limit Level 2, increase current set point by 2°F.

At Demand Limit Level 3, increase current set point by 4°F.

The operative set point shall be determined by the System's mode:

The set points shall be the occupied set point during Occupied mode, Warm-up mode, and Cool-down mode.

The set points shall be unoccupied set points during Unoccupied mode, Setback mode, and Setup mode.

Hierarchy of set point adjustments. The following adjustment restrictions shall prevail in order from highest to lowest priority:

Demand limit.

Local set point adjustment.

Scheduled set points based on System mode.

Local override. When thermostat override buttons are depressed, the request for Occupied Mode operation shall be sent up to the System control for 60 minutes. (This will cause all zones in the System to operate in Occupied Mode to ensure that the system has adequate load to operate stably (sic).)

Control Loops:

Two separate control loops shall operate to maintain space temperature at set point, the Cooling Loop and the Heating Loop. Both loops shall be continuously active.

Control Systems Design Guideline

The Cooling Loop shall maintain the space temperature at the active cooling set point. The output of the loop shall be a virtual point ranging from 0% (no cooling) to +100% (full cooling).

The Heating Loop shall maintain the space temperature at the active heating set point. The output of the loop shall be a virtual point ranging from 0% (no heating) to -100% (full heating).

Loops shall be use proportional + integral logic or fuzzy logic. Proportional-only control is not acceptable, although the integral gain shall be small relative to the proportional gain. P and I gains shall be adjustable from the Operator Workstation.

See other sections for how the outputs from these loops are used.

Zone Modes:

Heating Mode: when the output of the space heating control loop is less than zero.

Cooling Mode: when the output of the space cooling control loop is greater than zero and the output of the heating loop is equal to zero.

Deadband Mode: when not in either the Heating or Cooling Mode.

Alarms:

Inhibit alarms after zone set point is changed for a period of 10 minutes per degree of change (e.g. if set point changes from 68°F to 70°F, inhibit alarm for 20 minutes after the change) and while System is in Warm-up or Cool-down Modes.

If the zone is 2°F above cooling or below heating set point, generate Level 3 alarm.

If the zone is 4°F above cooling or below heating set point, generate Level 2 alarm.

System Operating Modes

Normal (Occupied) mode: A system is in the occupied mode when any of the following is true:

The time of day is between the System's scheduled occupied start and stop times. Note: Occupied start time shall be scheduled to be 1 hour before the building is expected to be occupied (for Title 24 required purge).

The schedules have been overridden by the web-based Occupant Interface override system

Any zone local override timer (initiated by local override button) is nonzero.

Warm-up mode. Warm-up start time shall be determined based on the zone in the System whose space temperature is furthest below its occupied heating temperature set point (excluding zones whose window switches indicate the window is open), the outside air temperature, and a building mass/capacity factor. This factor shall be manually adjusted or self-tuned by the program based on internal trending so that all zones in the System are brought up to their occupied set point by the scheduled occupied start hour. The tuning period mode shall be turned

Control Systems Design Guideline

on or off by a software switch (to allow tuning to be stopped after the system has been trained). Warm-up mode shall start no earlier than 3 hours before the scheduled occupied start hour and shall end at the scheduled occupied start hour.

Cool-down mode. Cool-down shall be determined based on the zone in the System whose space temperature is furthest above its occupied cooling temperature set point (excluding zones whose window switches indicate the window is open), the outside air temperature, and a building mass/capacity factor. This factor shall be manually adjusted or self-tuned by the program based on internal trending so that all zones in the System are brought down to their occupied set point by the scheduled occupied start hour. The tuning period mode shall be turned on or off by a software switch (to allow tuning to be stopped after the system has been trained). Cool-down mode shall start no earlier than 3 hours before the scheduled occupied start hour and shall end at the scheduled occupied start hour.

Setback mode. During other than normal mode, and warm-up mode, if any zone in the System falls 2°F below its active unoccupied setback set point, until all spaces in the System are above their active setback set points.

Setup mode. During other than normal mode, warm-up mode, and setback mode, if any zone in the isolation rises 2°F above its active unoccupied setup set point until all spaces in the System are below their active setup set points.

Unoccupied mode. When the System is not in any other mode.

Supply fan control. The unit fan shall run when system is in any mode other than Unoccupied Mode.

Minimum outdoor air damper position set point

Determine minimum position set point with balancer with supply fan on at design airflow rate. Actuators are direct coupled and expected to have repeatable minimum position. See section Testing, Adjusting, and Balancing.

Minimum position set point (Min OA) shall be open to at least minimum position when the supply air fan is proven on and the system is not in warm-up, cool-down, setup, or setback mode. Minimum position set point shall be zero otherwise.

Cooling supply air temperature control

Cooling supply air temperature loop is enabled when the supply air fan is proven on and zone is in Cooling Mode. When loop is disabled, slowly reduce loop output to zero to prevent sudden pressure changes in the CHW flow distribution system.

Cooling supply air temperature reset: Set point is reset from 53°F when the zone Cooling Loop is 100% proportionally up to the active zone set point temperature when zone Cooling Loop is 0%.

Control Systems Design Guideline

Supply air temperature shall be controlled to set point using a PID loop whose output is mapped to sequence the economizer dampers and chilled water valve as shown in the diagram below. Dampers and valves shall go to normal position (outdoor air damper closed, valve closed, return air damper open) when the loop is disabled. Min OA is the minimum damper position described above.

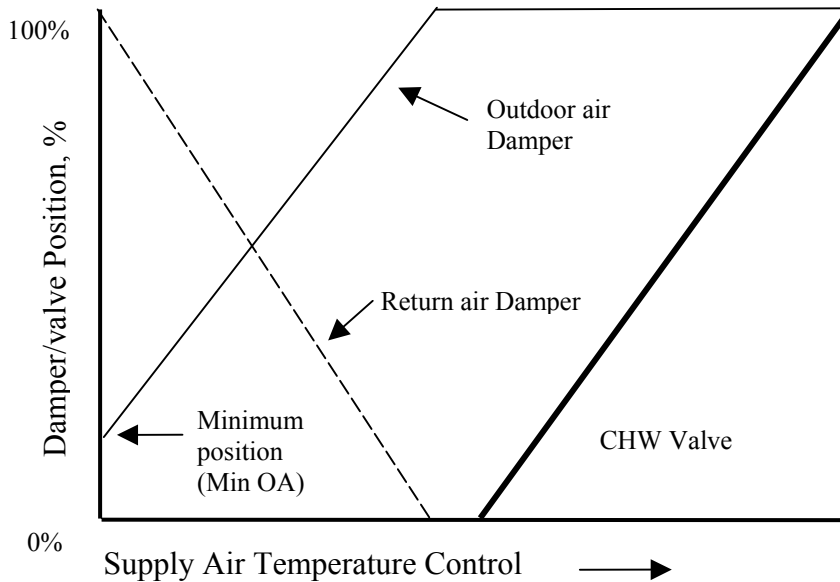

Economizer lockout: The normal sequencing of the economizer dampers (above) shall be overridden and economizer outdoor air dampers shall be shut to minimum set point signal whenever the outdoor air temperature is greater than room air temperature. Provide deadband to prevent short-cycling between modes.

Freeze protection. If the outdoor air temperature is less than 30°F for more than 30 minutes until the outdoor air temperature rises to above 32°F, minimum valve position shall be 15% regardless of fan status or any other operating mode, except when the fan is proven on and the heating coil valve position exceeds 10%.

Deadband Mode: Both heating and cooling supply air temperature loops shall be disabled and output set to zero.

Heating control.

Heating supply air temperature loop is enabled when the supply air fan is proven on and the zone is in Heating Mode. When loop is disabled, slowly reduce loop output to zero to prevent sudden pressure changes in the HW flow distribution system.

Heating supply air temperature reset: Set point is reset from 95°F when the zone Heating Loop is -100% proportionally down to active zone set point temperature when zone Heating Loop is 0%.

Control Systems Design Guideline

Heating supply air temperature shall be controlled by a PID loop modulating the heating coil control valve to maintain the supply air temperature at set point.

Freeze protection. If the outdoor air temperature is less than 30°F for more than 30 minutes until the outdoor air temperature rises to above 32°F, minimum valve position shall be 15% regardless of fan status or any other operating mode.

Alarms

Maintenance interval alarm when fan has operated for more than 1500 hours: Level 5. Reset interval counter when alarm is acknowledged.

Fan alarm is indicated by the status input being different from the output command after a period of 60 seconds after a change in output status.

Commanded on, status off: Level 2.

Commanded off, status on: Level 4.

Filter pressure drop exceeds adjustable alarm limit. Level 5

High supply air temperature ($> 2^{\circ}\text{F}$ above set point) off cooling coils when coil control loop is active for longer than 5 minutes. Level 3.

Low supply air temperature ($< 2^{\circ}\text{F}$ below set point) off heating coils when coil control loop is active for longer than 5 minutes. Level 2.

While heating valve is closed, if the temperature increase across the heating coil exceeds 2°F continuously for 30 minutes; or if the discharge temperature is more than 5°F above set point for more than 30 minutes continuously: Level 4 indicating possibly leaking valve.

While cooling valve is closed, if the temperature drop across the cooling coil exceeds 2°F continuously for 30 minutes; or if the discharge temperature is more than 5°F below set point for more than 30 minutes continuously: Level 4 indicating possibly leaking valve.

If mixed air temperature is less than 40°F or greater than 85°F ; OR if the outside air temperature is above the supply air temperature set point and the economizer is enabled and the mixed air temperature is more than 2°F different from the outside air temperature for more than 30 minutes continuously; OR if the outdoor air temperature is more than 5°F below the supply air temperature set point and the chilled water valve is open (or compressors are on): Level 4 indicating economizer damper control problems.

(End of document)